

# PYROVIEW 640N compact+

Infrared camera for measurement of high temperatures at 0.8  $\mu\text{m}$  to 1.1  $\mu\text{m}$



## Features

- Large continuous measurement range from 600 °C to 1500 °C, optional 2500 °C
- Measurement frequency 25 frames per second
- High dynamic 2D Si CMOS array with 640 × 480 pixels
- Robust aluminium compact housing
- Mounting option in combustion chamber sonde with cooling
- Real-time data acquisition via Fast Ethernet
- Option of stand alone operation without computer
- Triggered measurements
- Alarm and threshold monitoring
- 2 years warranty
- Customized system solutions with modified hardware and software

## Description and applications

PYROVIEW 640N compact+ camera provides non-contact measurement of 2D temperature distributions with high dynamic and high spatial resolution. The camera is specially designed for long-term use in harsh industrial environments.

Typical applications for the camera PYROVIEW 640N compact+ are measurements of high temperatures in process control and monitoring, as well as quality control in metal, glass and cement industries.

## Software

The powerful online software PYROSOFT for Windows ® allows you to control the camera and record, view, manipulate and store the measured data.

Special features are:

- Real-time data recording
- Definition of zones and monitoring of alarm thresholds
- Analysis of trends
- Data export (text, bitmap, video)
- Process control via PROFIBUS, analog and digital inputs, outputs, and other interfaces

A programming interface (Windows ®-DLL) is available for system integration.

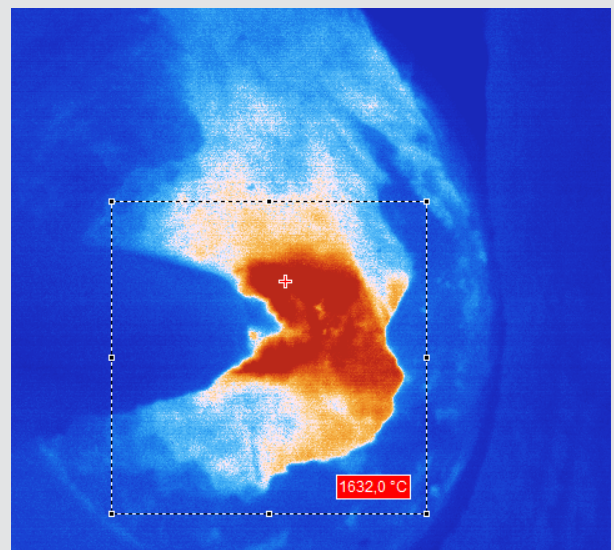

# PYROVIEW 640N compact+

Infrared camera for measurement of high temperatures at 0.8  $\mu\text{m}$  to 1.1  $\mu\text{m}$

## Technical data

Spectral range	0.8 $\mu\text{m}$ to 1.1 $\mu\text{m}$
Temperature measurement range <sup>1</sup>	600 °C to 1500 °C, optional 2500 °C
Sensor	high dynamic 2D Si CMOS array (640 × 480 pixels)
Lens <sup>1</sup>	32° × 24°, spatial range 0.9 mrad optional 46° × 35°, spatial range 1.3 mrad, optional 23° × 17°, spatial range 0.6 mrad, optional 17° × 13°, spatial range 0.5 mrad, optional 11° × 8°, spatial range 0.3 mrad, optional borescope lens 71° × 55°, spatial range 1.9 mrad (PYROINC 640N)
Measurement uncertainty <sup>2</sup>	2 % of the measured value in °C (object temperature > 1000 °C) <sup>3</sup>
Noise equivalent temperature difference <sup>2</sup>	< 2 K (600 °C, 25 Hz) <sup>4</sup>
Measurement frequency	internal 25 Hz, selectable: 25 Hz, 12,5 Hz, 6,25 Hz, ...
Response time	internal 80 ms, selectable: 2/measurement frequency
Interfaces	Fast Ethernet (real-time, 25 Hz)
Digital inputs	2 galvanically isolated inputs (trigger)
Digital outputs	2 galvanically isolated outputs (alarm)
Connectors <sup>3</sup>	round plug connector HR10A (12 pins, power supply, digital inputs and outputs), round plug M12A (Ethernet)
Power supply	12 V to 36 V DC, typically 7 VA
Housing	65 mm (W) × 160 mm (D) × 79 mm (H) (camera aluminium compact housing without lens) optional with weatherproof housing or furnace probe lens with cooling jacket (IP 65), incl. retract unit, auto-closure device, control and supply cabinet (PYROINC 640N)
Camera operating temperature	-10 °C to 50 °C (without water-cooling), -25 °C to 150 °C (with water-cooling)
Storage conditions	-20 °C to 70 °C, rel. humidity 95 % max
Software	Control and imaging software PYROSOFT for Windows ®, customized modifications on request

<sup>1</sup> Other available. <sup>2</sup> Specification for black body reference and ambient temperature 25 °C. <sup>3</sup> From 1000 °C additionally 0.75 % per 100 K increase of object temperature. <sup>4</sup> Additionally 0.75 K per 100 K increase of object temperature. Technical details are subject to change without notice. January 2012.

## Dimensions

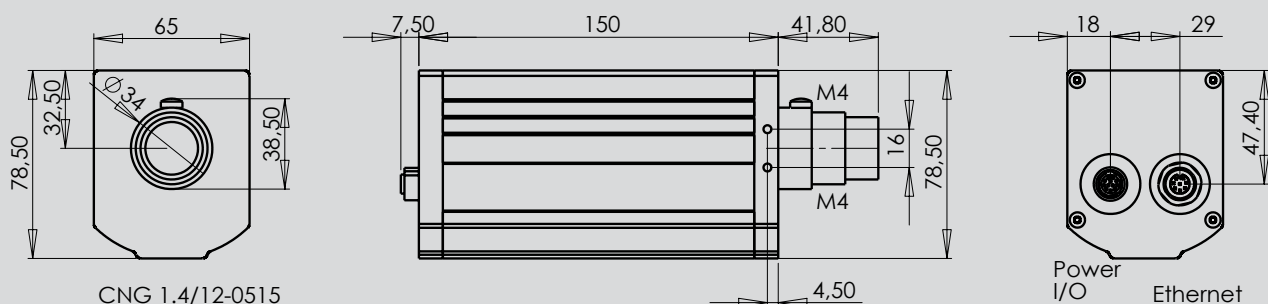

We are certified for many years according to ISO 9001

Phone: +49 351 871 7228  
Fax: +49 351 871 7230  
E-Mail: [info@dias-infrared.de](mailto:info@dias-infrared.de)  
Internet: [www.dias-infrared.com](http://www.dias-infrared.com)

DIAS Infrared GmbH  
Gostritzer Straße 65  
01217 Dresden  
Germany